

CHIUSURE IN ALLUMINIO PER VEICOLI LEGGERI

# SERIE BB3

alluminio anodizzato / anodized aluminium / eloxiert aluminium

chiusure per veicoli leggeri

locks for smaller lorries

alu-runge verschluß für klein fahrzeug

# SERIE BB3

**CHIUSURA CON MANIGLIA RIBALTABILE IN PLASTICA  
E GANCIO DI SICUREZZA**

*LOCK WITH PLASTIC OVERTURNING HANDLE  
AND SAFETY LEVER*

*ALU-VERSCHLUß ABKLAPPBAR KUNSTSTOFFHEBEL  
UND SICHERHEITSHANKEN*

## CHIUSURE IN ALLUMINIO PER VEICOLI LEGGERI

# SERIE BB3

alluminio anodizzato / anodized aluminium / eloxiert aluminium

chiusure per veicoli leggeri

locks for smaller lorries

alu-runge verschluß für klein fahrzeug

maniglia verticale ribaltabile / dropline lock with overturning handle / kunststoff vertikal alu-runge verschluß



## CHIUSURE IN ALLUMINIO PER VEICOLI LEGGERI

# SERIE BB3

alluminio anodizzato / anodized aluminium / eloxiert alluminium

chiusure per veicoli leggeri

locks for smaller lorries

alu-runge verschluß für klein fahrzeug

perno orizzontale con battuta / horizontal pin with wing / horizontal bolzen mit anschlag

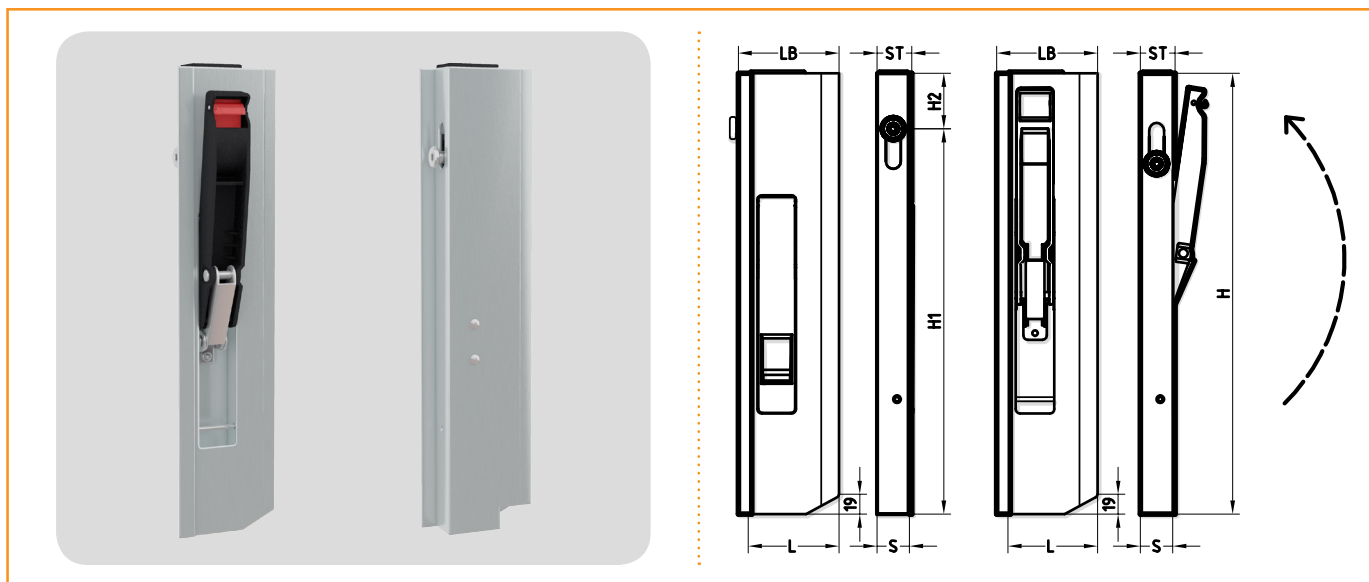

Articolo	Tipo	H	L	S	H1	H2	H3	LB	ST	Peso
08-8000D	Dx - maniglia verticale p.o. c.b. / with wing	310	76	29	250	60	-	89	32	0,520 Kg.
08-8000S	Sx - maniglia verticale p.o. c.b. / with wing	310	76	29	250	60	-	89	32	0,520 Kg.
08-8004D	Dx - maniglia verticale p.o. c.b. / with wing	360	76	29	300	60	-	89	32	0,585 Kg.
08-8004S	Sx - maniglia verticale p.o. c.b. / with wing	360	76	29	300	60	-	89	32	0,585 Kg.
08-8001D	Dx - maniglia verticale p.o. c.b. / with wing	410	76	29	350	60	-	89	32	0,650 Kg.
08-8001S	Sx - maniglia verticale p.o. c.b. / with wing	410	76	29	350	60	-	89	32	0,650 Kg.
08-8002D	Dx - maniglia verticale p.o. c.b. / with wing	510	76	29	350	60	-	89	32	0,750 Kg.
08-8002S	Sx - maniglia verticale p.o. c.b. / with wing	510	76	29	350	60	-	89	32	0,750 Kg.
08-8003D	Dx - maniglia verticale p.o. c.b. / with wing	610	76	29	350	60	-	89	32	0,855 Kg.
08-8003S	Sx - maniglia verticale p.o. c.b. / with wing	610	76	29	350	60	-	89	32	0,855 Kg.
08-8005D	Dx - maniglia verticale p.o. c.b. / with wing	810	76	29	350	60	-	89	32	1,065 Kg.
08-8005S	Sx - maniglia verticale p.o. c.b. / with wing	810	76	29	350	60	-	89	32	1,065 Kg.

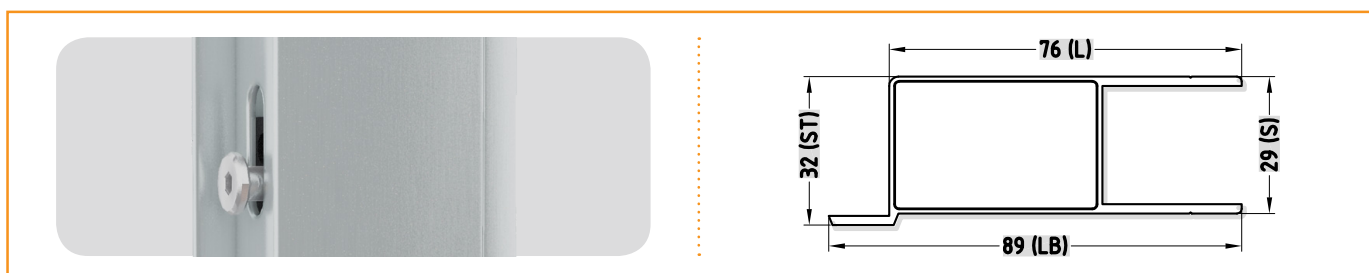

Dx = destra / right / rechts | Sx = sinistra / left / links | p.o. = perno orizzontale / horizontal pin / horizontal bolzen | c.b. = con battuta / with wing / mit anschlag

## CHIUSURE IN ALLUMINIO PER VEICOLI LEGGERI

# SERIE BB3

alluminio anodizzato / anodized aluminium / eloxiert alluminium

chiusure per veicoli leggeri

locks for smaller lorries

alu-runge verschluß für klein fahrzeug

perno orizzontale senza battuta / horizontal pin without wing / horizontal bolzen ohne anschlag

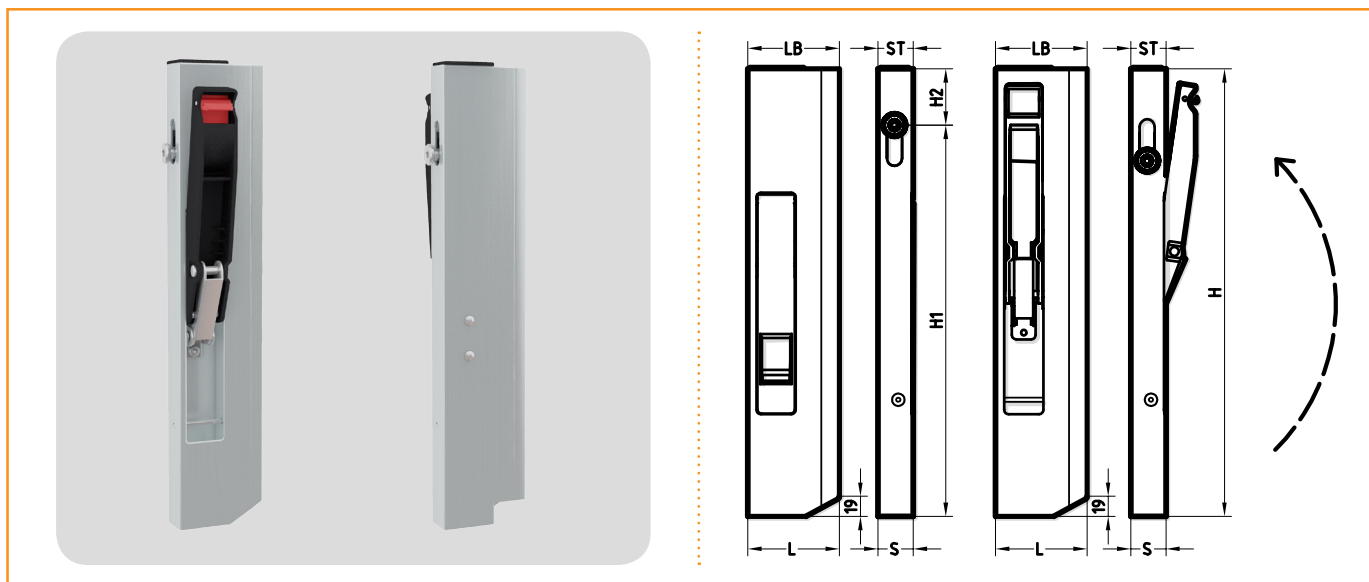

Articolo	Tipo	H	L	S	H1	H2	H3	LB	ST	Peso
08-8050D	Dx - maniglia verticale p.o. s.b. / with wing	310	76	29	250	60	-	76	29	0,500 Kg.
08-8050S	Sx - maniglia verticale p.o. s.b. / with wing	310	76	29	250	60	-	76	29	0,500 Kg.
08-8054D	Dx - maniglia verticale p.o. s.b. / with wing	360	76	29	300	60	-	76	29	0,575 Kg.
08-8054S	Sx - maniglia verticale p.o. s.b. / with wing	360	76	29	300	60	-	76	29	0,575 Kg.
08-8051D	Dx - maniglia verticale p.o. s.b. / with wing	410	76	29	350	60	-	76	29	0,625 Kg.
08-8051S	Sx - maniglia verticale p.o. s.b. / with wing	410	76	29	350	60	-	76	29	0,625 Kg.
08-8052D	Dx - maniglia verticale p.o. s.b. / with wing	510	76	29	350	60	-	76	29	0,720 Kg.
08-8052S	Sx - maniglia verticale p.o. s.b. / with wing	510	76	29	350	60	-	76	29	0,720 Kg.
08-8053D	Dx - maniglia verticale p.o. s.b. / with wing	610	76	29	350	60	-	76	29	0,820 Kg.
08-8053S	Sx - maniglia verticale p.o. s.b. / with wing	610	76	29	350	60	-	76	29	0,820 Kg.
08-8055D	Dx - maniglia verticale p.o. s.b. / with wing	810	76	29	350	60	-	76	29	1,015 Kg.
08-8055S	Sx - maniglia verticale p.o. s.b. / with wing	810	76	29	350	60	-	76	29	1,015 Kg.



Dx = destra / right / rechts | Sx = sinistra / left / links | p.o. = perno orizzontale / horizontal pin / horizontal bolzen | s.b. = senza battuta / without wing / ohne anschlag

## CHIUSURE IN ALLUMINIO PER VEICOLI LEGGERI

# SERIE BB3

alluminio anodizzato / anodized aluminium / eloxiert alluminium

chiusure per veicoli leggeri

locks for smaller lorries

alu-runge verschluß für klein fahrzeug

perno orizzontale doppia camera con battuta / horizontal pin double chamber with wing / horizontal bolzen doppelkammer mit anschlag

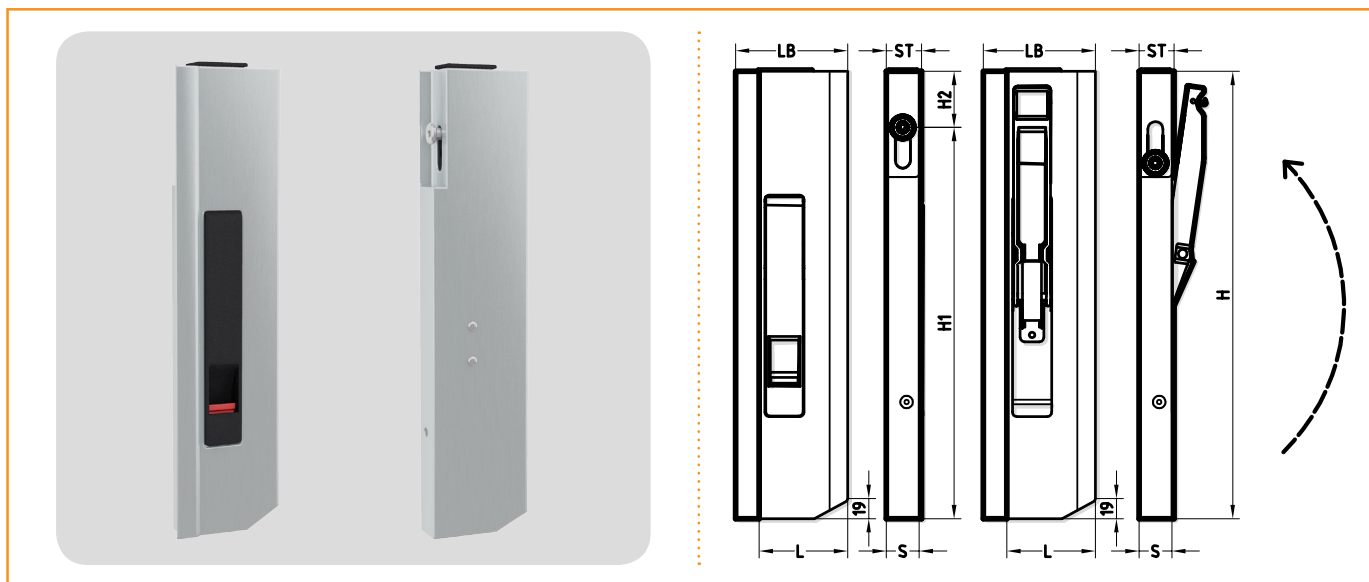

Articolo	Tipo	H	L	S	H1	H2	H3	LB	ST	Peso
08-8130D	Dx - maniglia verticale p.o. c.b. / with wing	310	87	29	250	60	-	96	32	0,550 Kg.
08-8130S	Sx - maniglia verticale p.o. c.b. / with wing	310	87	29	250	60	-	96	32	0,550 Kg.
08-8135D	Dx - maniglia verticale p.o. c.b. / with wing	360	87	29	300	60	-	96	32	0,625 Kg.
08-8135S	Sx - maniglia verticale p.o. c.b. / with wing	360	87	29	300	60	-	96	32	0,625 Kg.
08-8140D	Dx - maniglia verticale p.o. c.b. / with wing	410	87	29	350	60	-	96	32	0,700 Kg.
08-8140S	Sx - maniglia verticale p.o. c.b. / with wing	410	87	29	350	60	-	96	32	0,700 Kg.
08-8150D	Dx - maniglia verticale p.o. c.b. / with wing	510	87	29	350	60	-	96	32	0,815 Kg.
08-8150S	Sx - maniglia verticale p.o. c.b. / with wing	510	87	29	350	60	-	96	32	0,815 Kg.
08-8160D	Dx - maniglia verticale p.o. c.b. / with wing	610	87	29	350	60	-	96	32	0,935 Kg.
08-8160S	Sx - maniglia verticale p.o. c.b. / with wing	610	87	29	350	60	-	96	32	0,935 Kg.
08-8180D	Dx - maniglia verticale p.o. c.b. / with wing	810	87	29	350	60	-	96	32	1,165 Kg.
08-8180S	Sx - maniglia verticale p.o. c.b. / with wing	810	87	29	350	60	-	96	32	1,165 Kg.

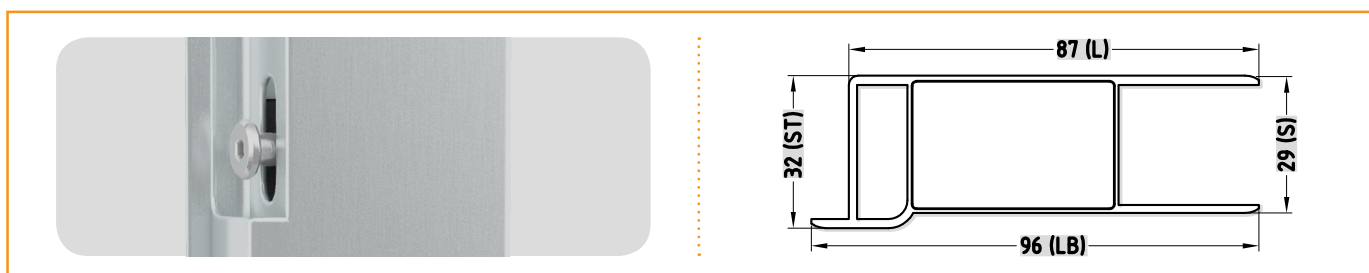

Dx = destra / right / rechts | Sx = sinistra / left / links | p.o. = perno orizzontale / horizontal pin / horizontal bolzen | c.b. = con battuta / with wing / mit anschlag

## CHIUSURE IN ALLUMINIO PER VEICOLI LEGGERI

# SERIE BB3

alluminio anodizzato / anodized aluminium / eloxiert alluminium

chiusure per veicoli leggeri

locks for smaller lorries

alu-runge verschluß für klein fahrzeug

perno orizzontale doppia camera senza battuta / horizontal pin double chamber without wing / horizontal bolzen doppelkammer ohne anschlag

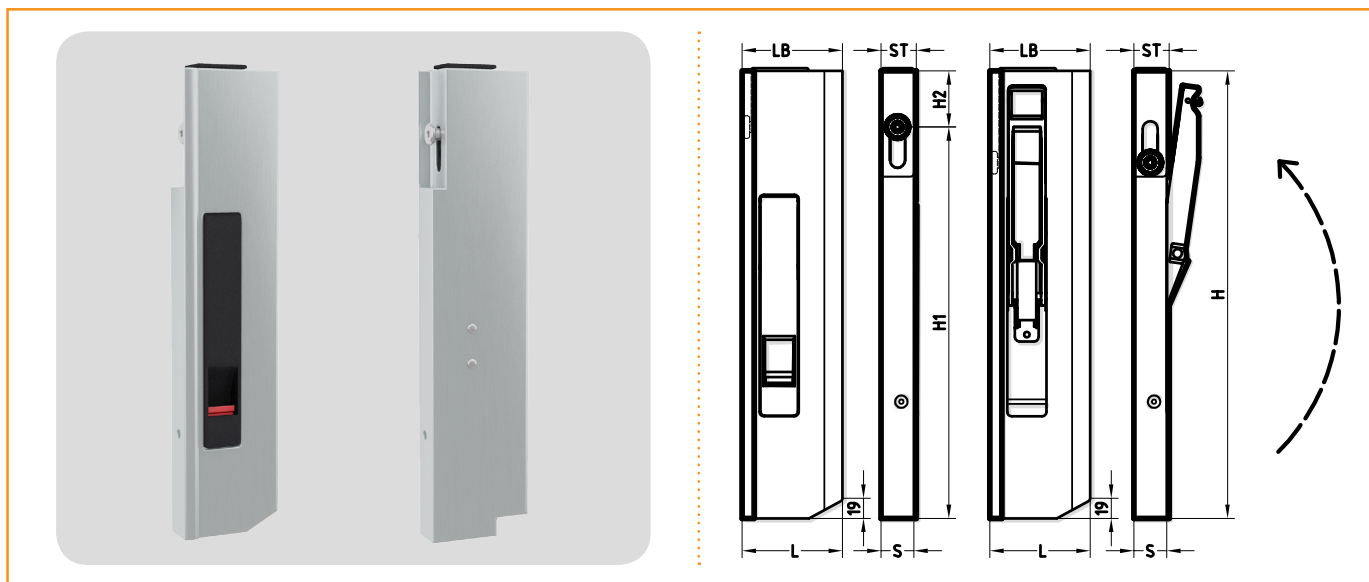

Articolo	Tipo	H	L	S	H1	H2	H3	LB	ST	Peso
08-8230D	Dx - maniglia verticale doppia camera p.o. s.b.	310	87	30	250	60	-	87	32	0,555 Kg.
08-8230S	Sx - maniglia verticale doppia camera p.o. s.b.	310	87	30	250	60	-	87	32	0,555 Kg.
08-8235D	Dx - maniglia verticale doppia camera p.o. s.b.	360	87	30	300	60	-	87	32	0,630 Kg.
08-8235S	Sx - maniglia verticale doppia camera p.o. s.b.	360	87	30	300	60	-	87	32	0,630 Kg.
08-8240D	Dx - maniglia verticale doppia camera p.o. s.b.	410	87	30	350	60	-	87	32	0,705 Kg.
08-8240S	Sx - maniglia verticale doppia camera p.o. s.b.	410	87	30	350	60	-	87	32	0,705 Kg.
08-8250D	Dx - maniglia verticale doppia camera p.o. s.b.	510	87	30	350	60	-	87	32	0,830 Kg.
08-8250S	Sx - maniglia verticale doppia camera p.o. s.b.	510	87	30	350	60	-	87	32	0,830 Kg.
08-8260D	Dx - maniglia verticale doppia camera p.o. s.b.	610	87	30	350	60	-	87	32	0,950 Kg.
08-8260S	Sx - maniglia verticale doppia camera p.o. s.b.	610	87	30	350	60	-	87	32	0,950 Kg.
08-8280D	Dx - maniglia verticale doppia camera p.o. s.b.	810	87	30	350	60	-	87	32	1,200 Kg.
08-8280S	Sx - maniglia verticale doppia camera p.o. s.b.	810	87	30	350	60	-	87	32	1,200 Kg.

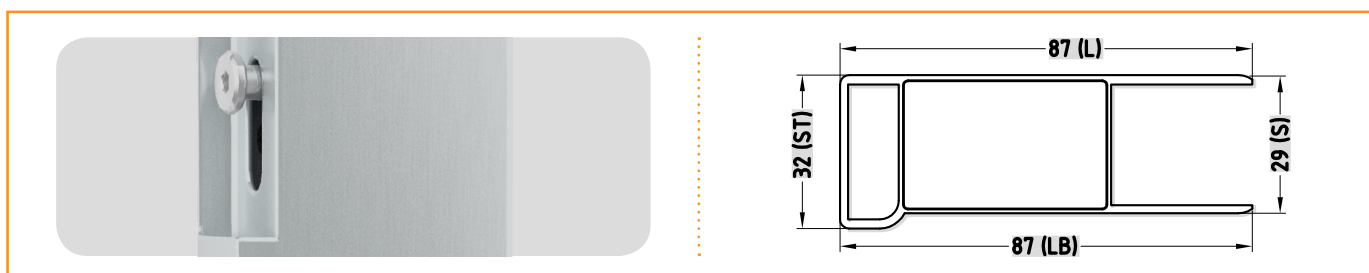

Dx = destra / right / rechts | Sx = sinistra / left / links | p.o. = perno orizzontale / horizontal pin / horizontal bolzen | s.b. = senza battuta / without wing / ohne anschlag

## CHIUSURE IN ALLUMINIO PER VEICOLI LEGGERI

# SERIE BB3

alluminio anodizzato / anodized aluminium / eloxiert alluminium

chiusure per veicoli leggeri

locks for smaller lorries

alu-runge verschluß für klein fahrzeug

perno verticale con battuta / vertical pin with wing / vertical bolzen mit anschlag

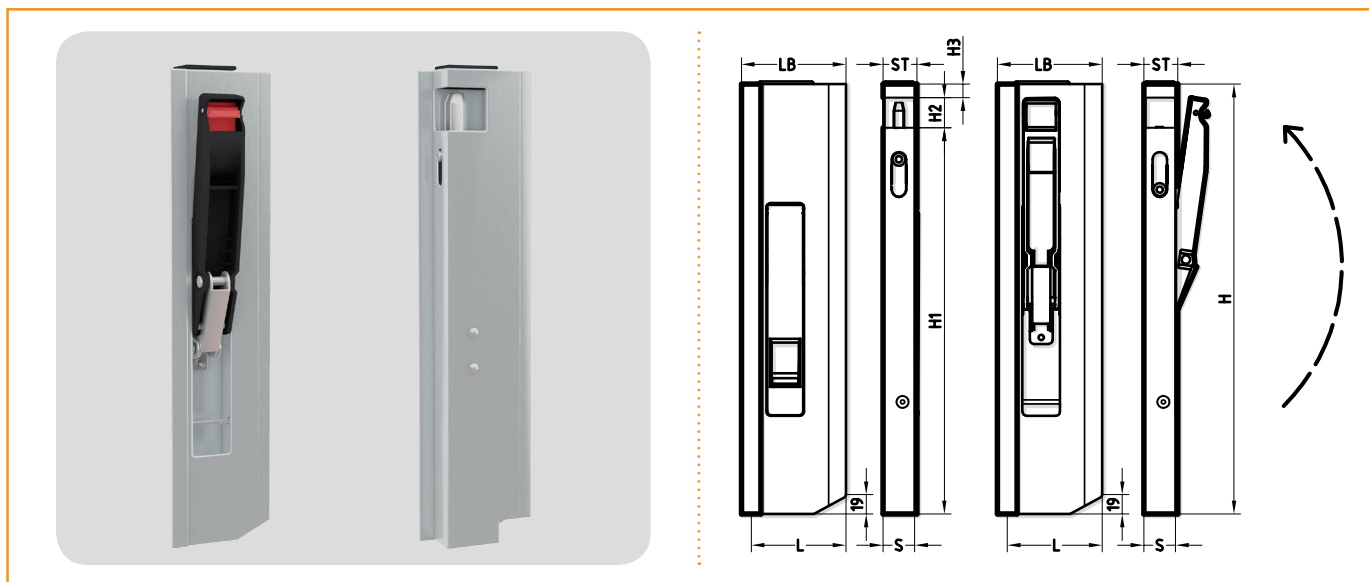

Articolo	Tipo	H	L	S	H1	H2	H3	LB	ST	Peso
08-8430D	Dx - maniglia verticale p.v. c.b. / with wing	310	76	29	261	34	15	87	32	0,540 Kg.
08-8430S	Sx - maniglia verticale p.v. c.b. / with wing	310	76	29	261	34	15	87	32	0,540 Kg.
08-8435D	Dx - maniglia verticale p.v. c.b. / with wing	360	76	29	311	34	15	87	32	0,595 Kg.
08-8435S	Sx - maniglia verticale p.v. c.b. / with wing	360	76	29	311	34	15	87	32	0,595 Kg.
08-8440D	Dx - maniglia verticale p.v. c.b. / with wing	410	76	29	361	34	15	87	32	0,645 Kg.
08-8440S	Sx - maniglia verticale p.v. c.b. / with wing	410	76	29	361	34	15	87	32	0,645 Kg.
08-8450D	Dx - maniglia verticale p.v. c.b. / with wing	510	76	29	461	34	15	87	32	0,750 Kg.
08-8450S	Sx - maniglia verticale p.v. c.b. / with wing	510	76	29	461	34	15	87	32	0,750 Kg.
08-8460D	Dx - maniglia verticale p.v. c.b. / with wing	610	76	29	561	34	15	87	32	0,855 Kg.
08-8460S	Sx - maniglia verticale p.v. c.b. / with wing	610	76	29	561	34	15	87	32	0,855 Kg.
08-8480D	Dx - maniglia verticale p.v. c.b. / with wing	810	76	29	761	34	15	87	32	1,085 Kg.
08-8480S	Sx - maniglia verticale p.v. c.b. / with wing	810	76	29	761	34	15	87	32	1,085 Kg.

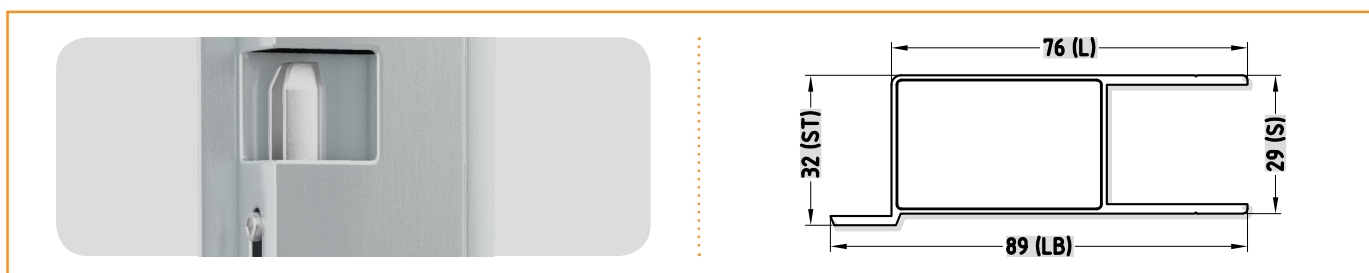

Dx = destra / right / rechts | Sx = sinistra / left / links | p.v. = perno verticale / vertical pin / vertikalen pin | c.b. = con battuta / with wing / mit anschlag

## CHIUSURE IN ALLUMINIO PER VEICOLI LEGGERI

# SERIE BB3

alluminio anodizzato / anodized aluminium / eloxiert alluminium

chiusure per veicoli leggeri

locks for smaller lorries

alu-runge verschluß für klein fahrzeug

perno verticale senza battuta / vertical pin without wing / vertical bolzen ohne anschlag

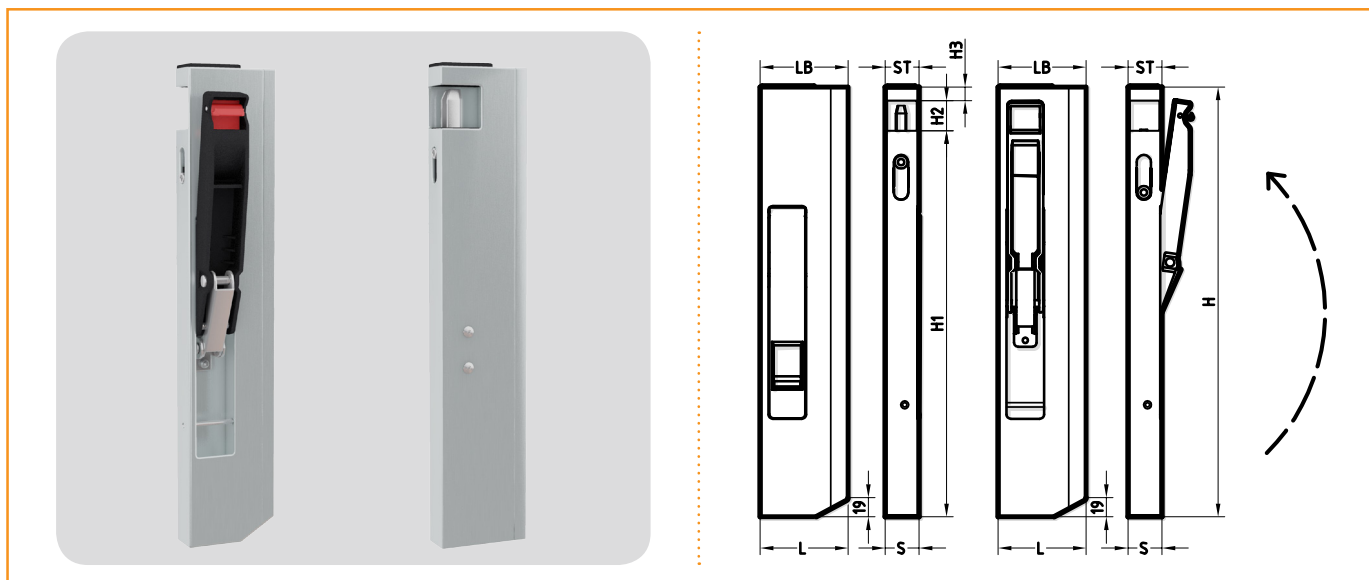

Articolo	Tipo	H	L	S	H1	H2	H3	LB	ST	Peso
08-8330D	Dx - maniglia verticale p.v. s.b.	310	76	29	261	34	15	76	29	0,520 Kg.
08-8330S	Sx - maniglia verticale p.v. s.b.	310	76	29	261	34	15	76	29	0,520 Kg.
08-8335D	Dx - maniglia verticale p.v. s.b.	360	76	29	311	34	15	76	29	0,575 Kg.
08-8335S	Sx - maniglia verticale p.v. s.b.	360	76	29	311	34	15	76	29	0,575 Kg.
08-8340D	Dx - maniglia verticale p.v. s.b.	410	76	29	361	34	15	76	29	0,625 Kg.
08-8340S	Sx - maniglia verticale p.v. s.b.	410	76	29	361	34	15	76	29	0,625 Kg.
08-8350D	Dx - maniglia verticale p.v. s.b.	510	76	29	461	34	15	76	29	0,730 Kg.
08-8350S	Sx - maniglia verticale p.v. s.b.	510	76	29	461	34	15	76	29	0,730 Kg.
08-8360D	Dx - maniglia verticale p.v. s.b.	610	76	29	561	34	15	76	29	0,845 Kg.
08-8360S	Sx - maniglia verticale p.v. s.b.	610	76	29	561	34	15	76	29	0,845 Kg.
08-8380D	Dx - maniglia verticale p.v. s.b.	810	76	29	761	34	15	76	29	1,010 Kg.
08-8380S	Sx - maniglia verticale p.v. s.b.	810	76	29	761	34	15	76	29	1,010 Kg.



Dx = destra / right / rechts | Sx = sinistra / left / links | p.v. = perno verticale / vertical pin / vertikalen pin | s.b. = senza battuta / without wing / ohne anschlag